

- ① 2 #4 VERTICAL CORNER BAR MINIMUM
- ② VERTICAL REINFORCING # 4 @ 48" O.C. MAX.
- ③ HORIZONTAL REINFORCING #4 @ 48" O.C. MAX
- ④ ICF CORNER BLOCK

**NOTE:**

ICF SCREEN GRID TO BE PER CURRENT IRC FOOTING WIDTH, REBAR SIZE AND SPACING PER SECTION R608 - IRC

DRAWN	KD
CHECKED	
DATE	06-22-20
SCALE	3/4" = 1'-0"
FILE NAME	EF BLOCK
DETAILS	
SHEET	D.1
	1 OF 1 SHEETS

WALL CORNER  
12" O.C. SCREEN GRID ICF

1720 E. CURRY RD.  
TEMPE ARIZONA 85281  
<http://www.efbm.com/>

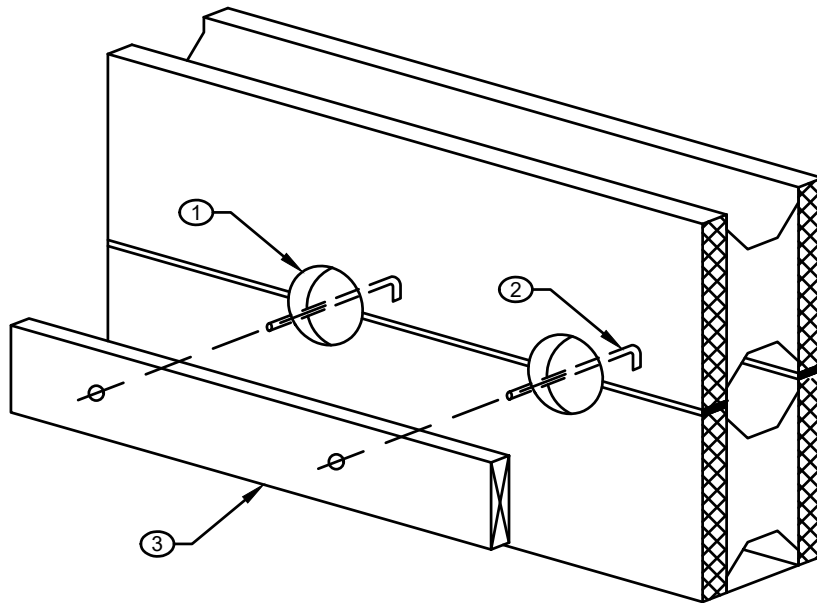

- ① CUT CONCRETE FORMS TO PROVIDE A 4" DIAMETER CONCRETE BEARING SURFACE AT ANCHOR BOLTS
- ② ANCHOR BOLTS PER DESIGN
- ③ LEDGER PER DESIGN

**NOTE:**  
 ICF SCREEN GRID TO BE PER CURRENT IRC FOOTING WIDTH, REBAR SIZE AND SPACING  
 PER SECTION R608 - IRC

DRAWN	KD
CHECKED	
DATE	06-22-20
SCALE	3/4" = 1'-0"
EF BLOCK	
FILE NAME	DETAILS
SHEET	D.2
1 OF 1 SHEETS	

LEDGER AT ICF WALL  
 12" O.C. SCREEN GRID ICF

1720 E. CURRY RD.  
 TEMPE ARIZONA 85281  
<http://www.efbm.com/>



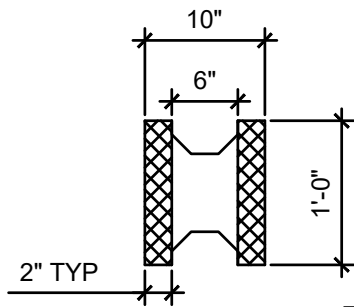

**A BLOCK ELEMENT**

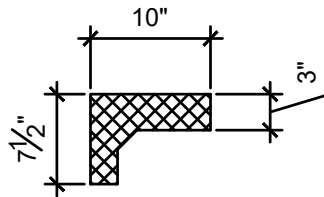

**C CORNER ELEMENT**

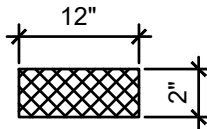

**D 2" FLAT**

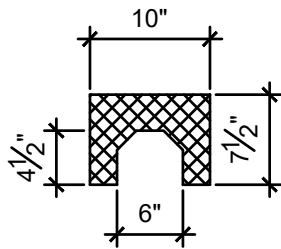

**B END ELEMENT**

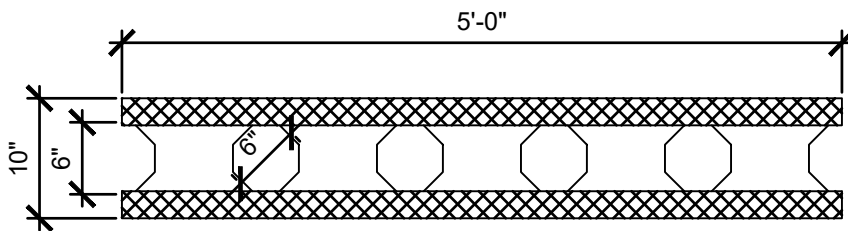

**E TOP BLOCK**

- ① ICF BLOCK MUST BE GROUDED SOLID WITH MINIMUM 2500 PSI
- ② PLACING OF CONCRETE INTO THE CORES SHALL COMPLY WITH ACI 318 SECTION 5.10
- ③ REINFORCING  $f_y = 40,000$  PSI FOR #4 BARS AND SMALLER AND  $f_y = 60,000$  PSI FOR #5 BARS AND GREATER
- ④ INSTALLATION OF ICF BLOCK MAY BE ERECTED IN A VERTICAL OR HORIZONTAL POSITION WITH ALL HOLLOWED CELLS ALIGNED
- ⑤ ALL WALLS SHALL BE BRACED ADEQUATELY TO RESIST ALL LOADS DURING THE PLACEMENT OF CONCRETE
- ⑥ ALL CELLS SHALL BE GROUDED SOLID
- ⑦ VERTICAL AND HORIZONTAL SPACING OF REINFORCING BARS SHALL BE 48" O.C. MAXIMUM. REFER TO ENGINEERING PLANS OR CURRENT IRC CODE FOR SPECIAL REINFORCING REQUIREMENTS

**NOTE:**

ICF SCREEN GRID TO BE PER CURRENT IRC FOOTING WIDTH, REBAR SIZE AND SPACING PER SECTION R608 - IRC

DRAWN
NO
CHECKED
DATE
08-22-20
SCALE
3/4" = 1'-0"
FILE NAME
EF BLOCK
DETAILS
SHEET
D.3
1 OF 1 SHEETS

**ICF WALL STANDARDS**  
**12" O.C. SCREEN GRID ICF**

1720 E. CURRY RD.  
TEMPE ARIZONA 85281  
<http://www.efbm.com/>



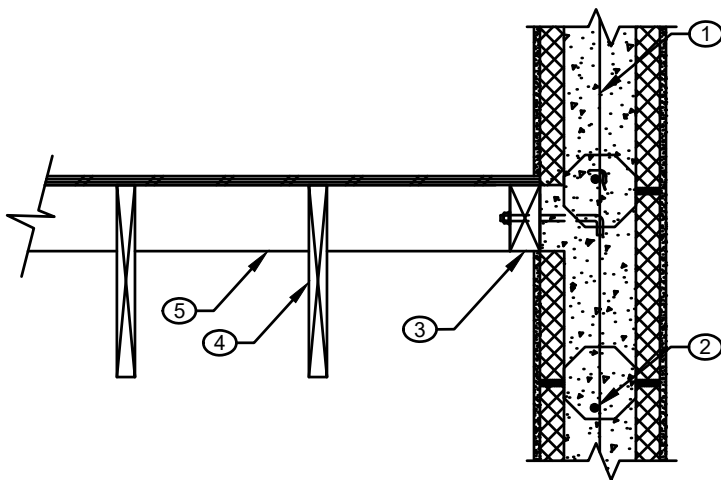

- ① HORIZONTAL REINFORCING # 4 @ 48"O.C. MAX.
- ② VERTICAL REINFORCING # 4 @ 48"O.C. MAX.
- ③ 2X LEDGER. CUT CONCRETE FORMS TO PROVIDE A 4" DIAMETER CONCRETE BEARING SURFACE AT ANCHOR BOLTS
- ④ FLOOR JOIST PER DESIGN
- ⑤ TRUSS BLOCKING PER TRUSS MFGR.

**NOTE:**

ICF SCREEN GRID TO BE PER CURRENT IRC FOOTING WIDTH, REBAR SIZE AND SPACING  
 PER SECTION R608 - IRC

DRAWN	KD
CHECKED	
DATE	06-22-20
SCALE	3/4" = 1'-0"
EF BLOCK	
FILE NAME	DETAILS
SHEET	D.4
1 OF 1 SHEETS	

FLOOR LEDGER AT ICF WALL  
 12" O.C. SCREEN GRID ICF

1720 E. CURRY RD.  
 TEMPE ARIZONA 85281  
<http://www.efbm.com/>

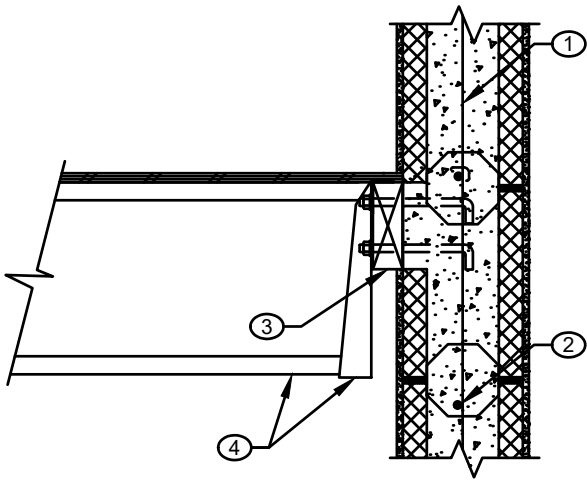

- ① HORIZONTAL REINFORCING # 4 @ 48"O.C. MAX.
- ② VERTICAL REINFORCING # 4 @ 48"O.C. MAX.
- ③ LEDGER PER DESIGN. CUT CONCRETE FORMS TO PROVIDE A 4" DIAMETER CONCRETE BEARING SURFACE AT ANCHOR BOLTS
- ④ FLOOR JOIST AND HANGER PER DESIGN

**NOTE:**  
 ICF SCREEN GRID TO BE PER CURRENT IRC FOOTING WIDTH, REBAR SIZE AND SPACING  
 PER SECTION R608 - IRC

DRAWN	KD
CHECKED	
DATE	06-22-20
SCALE	3/4" = 1'-0"
EF BLOCK	
FILE NAME	DETAILS
SHEET	D.5
1 OF 1 SHEETS	

TYP. FLOOR TRUSS AT ICF WALL  
 12" O.C. SCREEN GRID ICF

1720 E. CURRY RD.  
 TEMPE ARIZONA 85281  
<http://www.efbm.com/>

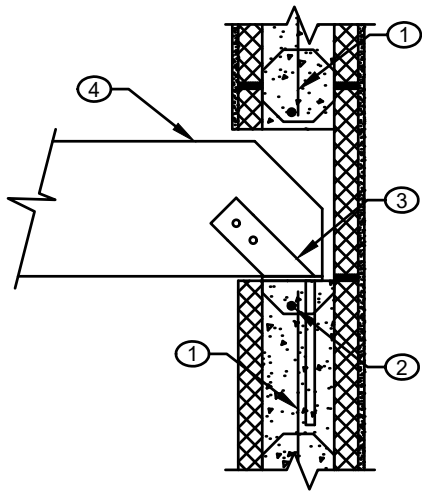

- ① HORIZONTAL REINFORCING # 4 @ 48"O.C. MAX.
- ② VERTICAL REINFORCING # 4 @ 48"O.C. MAX.
- ③ SIMPSON GLB5A
- ④ WOOD BEAM PER DESIGN

**NOTE:**  
 ICF SCREEN GRID TO BE PER CURRENT  
 IRC FOOTING WIDTH, REBAR SIZE AND  
 SPACING  
 PER SECTION R608 - IRC

DRAWN
KD
CHECKED
DATE
06-22-20
SCALE
3/4" = 1'-0"
BY BLOCK
FILE NAME
DETAILS
SHEET
D.6
1 OF 1 SHEETS

WOOD BEAM AT ICF WALL  
 12" O.C. SCREEN GRID ICF

1720 E. CURRY RD.  
 TEMPE ARIZONA 85281  
<http://www.efbm.com/>



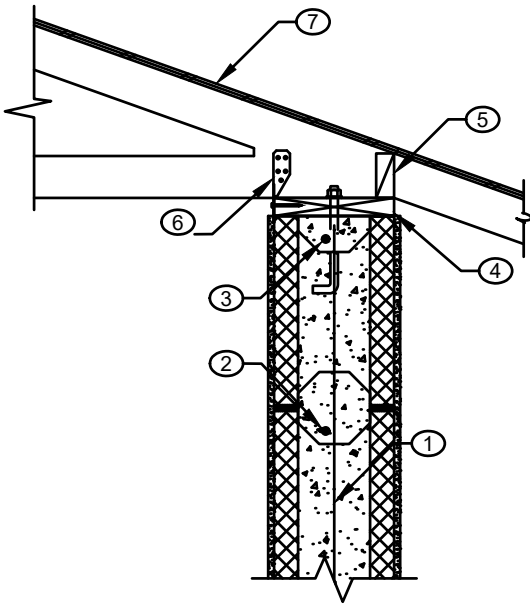

- ① HORIZONTAL REINFORCING # 4 @ 48"O.C. MAX.
- ② VERTICAL REINFORCING # 4 @ 48"O.C. MAX.
- ③ BOND BEAM WITH (1) #4 CONTINUOUS BAR
- ④ 2X TOP PLATE WITH 1/2" DIAMETER ANCHOR BOLTS AT 48" O.C.
- ⑤ 2X SOLID BLOCKING BETWEEN TRUSSES
- ⑥ H2.5 CLIP TO EACH ROOF TRUSS. FASTENED DIRECTLY TO TOP PLATE
- ⑦ STRUCTURAL SHEATHING

**NOTE:**

ICF SCREEN GRID TO BE PER CURRENT IRC FOOTING WIDTH, REBAR SIZE AND SPACING  
PER SECTION R608 - IRC

DRAWN	KD
CHECKED	
DATE	06-22-20
SCALE	3/4" = 1'-0"
BY BLOCK	
FILE NAME	DETAILS
SHEET	D.7
1 OF 1 SHEETS	

TYP ROOF TRUSS AT ICF WALL  
12" O.C. SCREEN GRID ICF

1720 E. CURRY RD.  
TEMPE ARIZONA 85281  
<http://www.efbm.com/>

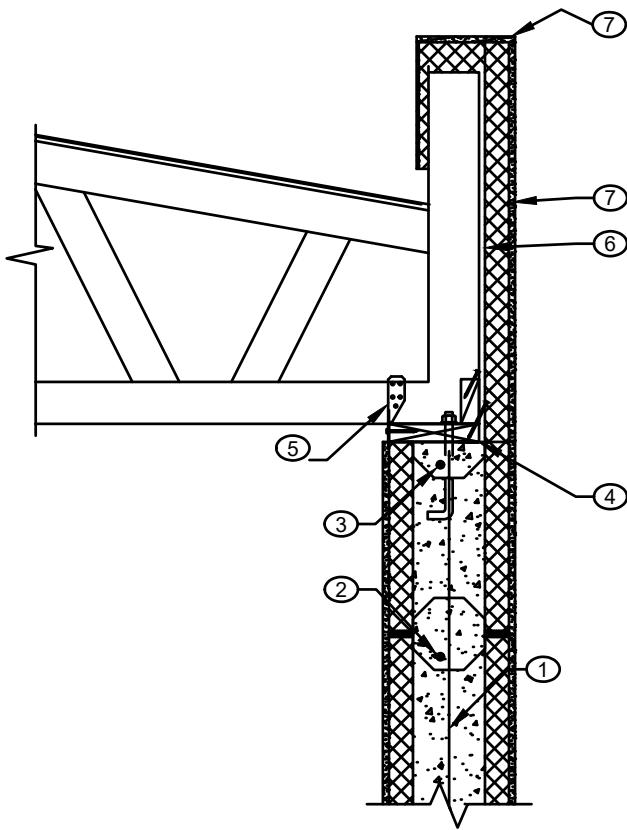

- ① HORIZONTAL REINFORCING # 4 @ 48" O.C. MAX.
- ② VERTICAL REINFORCING # 4 @ 48" O.C. MAX.
- ③ BOND BEAM WITH (1) #4 CONTINUOUS BAR
- ④ 2X TOP PLATE WITH 1/2" DIAMETER ANCHOR BOLTS AT 48" O.C.
- ⑤ H2.5 CLIP TO EACH ROOF TRUSS. FASTENED DIRECTLY TO TOP NAILER
- ⑥ STRUCTURAL SHEATHING W/ 30# FELT
- ⑦ FOAM EPS WITH LATH OVERLAPPING ICF MIN. 12"

**NOTE:**

ICF SCREEN GRID TO BE PER CURRENT IRC FOOTING WIDTH, REBAR SIZE AND SPACING  
PER SECTION R608 - IRC

DRAWN	MD
CHECKED	
DATE	06-22-20
SCALE	3/4" = 1'-0"
EF BLOCK	
FILE NAME	DETAILS
SHEET	D.8
1 OF 1 SHEETS	

TRUSS W/ PARAPET AT ICF WAL  
12" O.C. SCREEN GRID ICF

1720 E. CURRY RD.  
TEMPE ARIZONA 85281  
<http://www.efbm.com/>



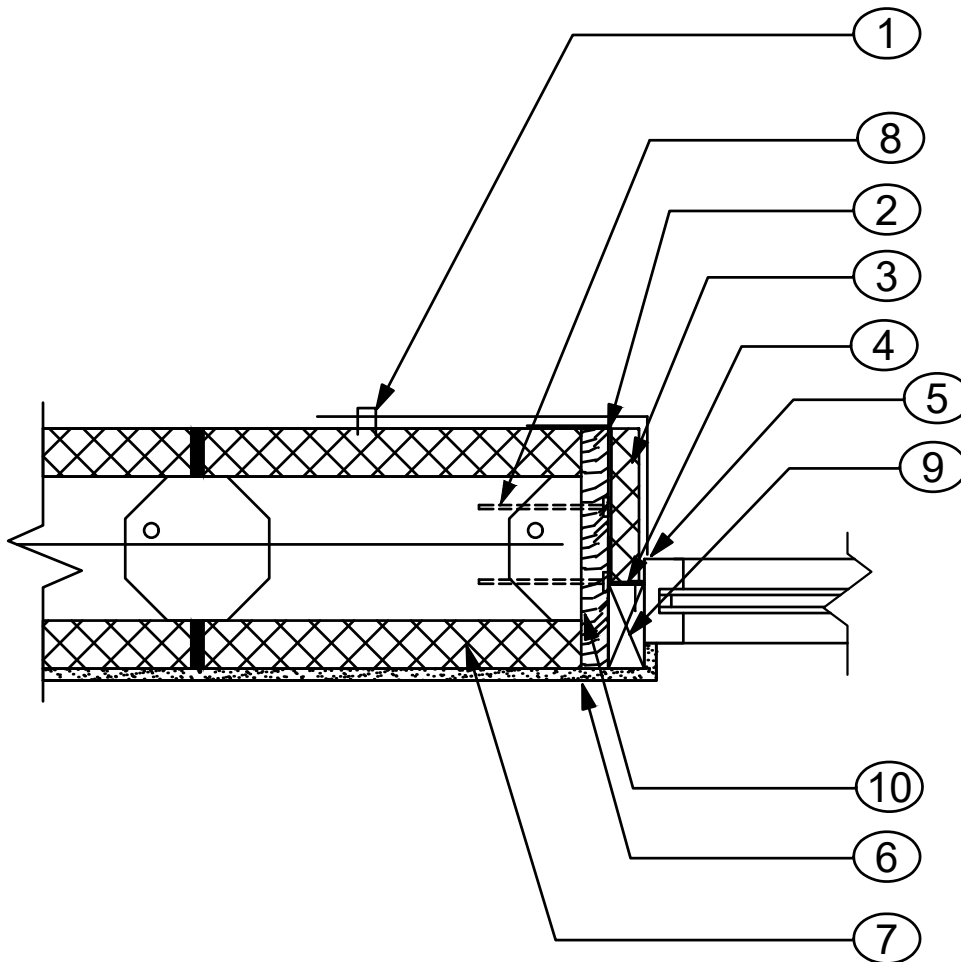

- ① CHICKEN WIRE STAPLED TO EF BLOCK WITH 12" LAP
- ② FLASHING
- ③ EPS OR SCRAP EF BLOCK
- ④ NAIL ON FLANGE WINDOW
- ⑤ SEALANT
- ⑥ 1/2" GWB
- ⑦ ICCF BLOCK
- ⑧ 3" DECK SCREWS @ 36" O.C.
- ⑨ 2X SECONDARY BUCKING
- ⑩ 3/4" PRIMARY BUCKING

**NOTE:**

ICF SCREEN GRID TO BE PER CURRENT IRC FOOTING WIDTH, REBAR SIZE AND SPACING PER SECTION R608 - IRC

DRAWN	KD
CHECKED	
DATE	06-22-20
SCALE	3/4" = 1'-0"
FILE NAME	EF BLOCK
DETAILS	
SHEET	D.9
	1 OF 1 SHEETS

## WINDOW JAMB DETAIL

### 12" O.C. SCREEN GRID ICF

1720 E. CURRY RD.  
 TEMPE ARIZONA 85281  
<http://www.efbm.com/>



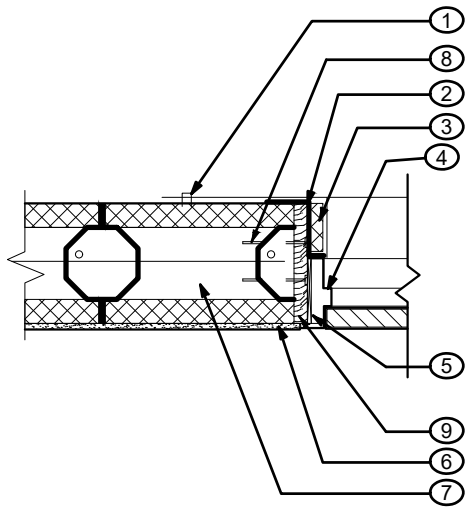

- ① CHICKEN WIRE STAPLED TO EF BLOCK WITH 12" LAP
- ② FLASHING
- ③ EPS OR SCRAP EF BLOCK
- ④ DOOR FRAME AND STOP
- ⑤ SHIM SPACE
- ⑥ PLASTER
- ⑦ ICF BLOCK
- ⑧ 3" DECK SCREWS @ 36" O.C.
- ⑨  $\frac{3}{4}$ " PRIMARY BUCKING

**NOTE:**  
 ICF SCREEN GRID TO BE PER CURRENT IRC FOOTING WIDTH, REBAR SIZE AND SPACING PER SECTION R608 - IRC

DRAWN	KD
CHECKED	
DATE	06-22-20
SCALE	3/4" = 1'-0"
EF BLOCK	
FILE NAME	DETAILS
SHEET	D.10
1	OF 1 SHEETS

DOOR JAMB DETAIL  
 12" O.C. SCREEN GRID ICF

1720 E. CURRY RD.  
 TEMPE ARIZONA 85281  
<http://www.efbm.com/>



- ① FINISHED GRADE
- ② 12" MINIMUM BELOW FINISH GRADE
- ③ 2- #4 HORIZONTAL DOWELS CONT.
- ④ VERTICAL DOWELS TO MATCH ICF WALL VERTICAL REINFORCING ALTERNATE BENDS
- ⑤ 6X6 #10 WWM OR #3 @ 48" O.C.
- ⑥ ICF TYPICAL HORIZONTAL REINFORCING
- ⑦ 4" THICK CONCRETE SLAB OVER 4" ABC FILL
- ⑧ LAP REINFORCING BARS PER 40 DIAMETERS

**NOTE:**  
 ICF SCREEN GRID TO BE PER CURRENT IRC FOOTING WIDTH, REBAR SIZE AND SPACING  
 PER SECTION R608 - IRC

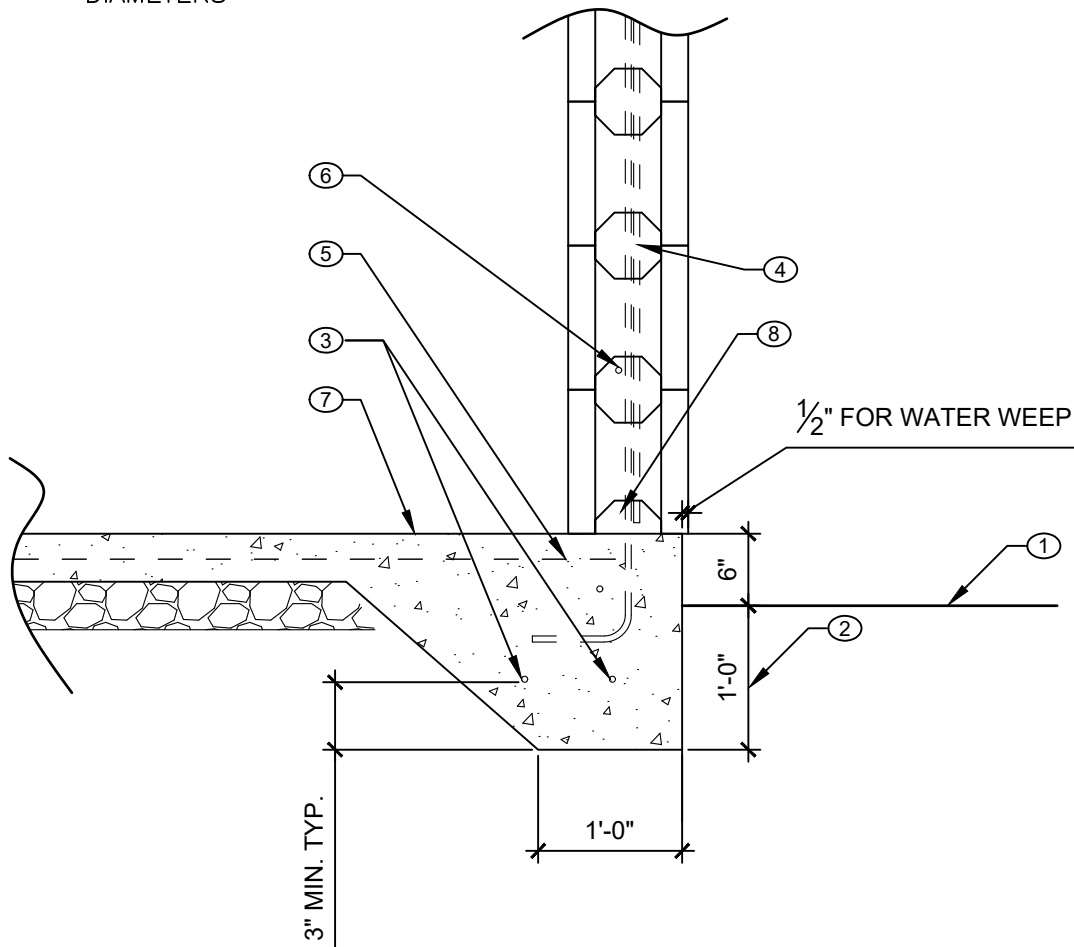

DRAWN	KD
CHECKED	
DATE	06-22-20
SCALE	3/4" = 1'-0"
EF BLOCK	
FILE NAME	DETAILS
SHEET	
D.11	
1 OF 1 SHEETS	

ICF WALL @ MONO FOOTING  
 12" O.C. SCREEN GRID ICF

1720 E. CURRY RD.  
 TEMPE ARIZONA 85281  
<http://www.efbm.com/>

- ① FINISHED GRADE
- ② 12" MINIMUM BELOW FINISH GRADE
- ③ 2- #4 HORIZONTAL DOWELS CONT.
- ④ VERTICAL DOWELS TO MATCH ICF WALL VERTICAL REINFORCING ALTERNATE BENDS
- ⑤ 6X6 #10 WWM OR #3 @ 48" O.C.
- ⑥ ICF TYPICAL HORIZONTAL REINFORCING
- ⑦ 4" THICK CONCRETE SLAB OVER 4" ABC FILL
- ⑧ LAP REINFORCING BARS PER 40 DIAMETERS

**NOTE:**  
 ICF SCREEN GRID TO BE PER CURRENT IRC FOOTING WIDTH, REBAR SIZE AND SPACING  
 PER SECTION R608 - IRC

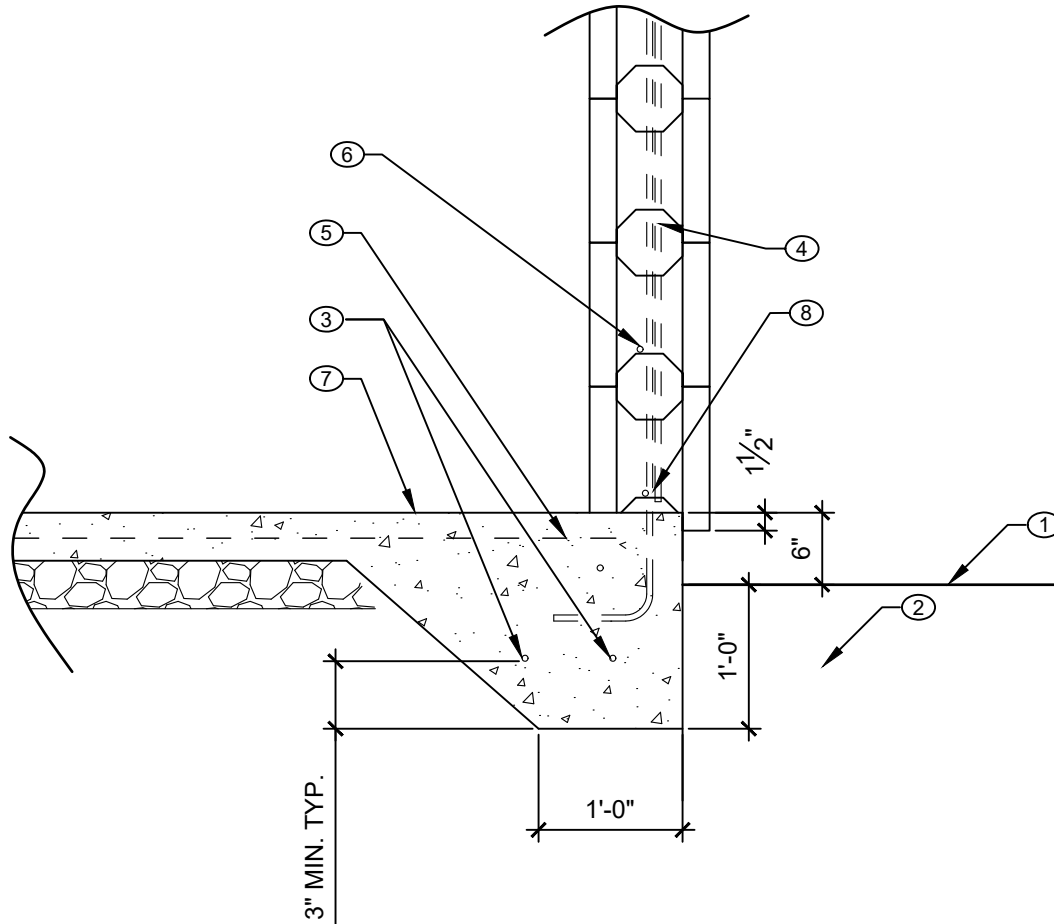

DRAWN	MD
CHECKED	
DATE	06-22-20
SCALE	3/4" = 1'-0"
BY BLOCK	
FILE NAME	DETAILS
SHEET	D.12
1	OF 1 SHEETS

ICF WALL @ MONO FOOTING  
 12" O.C. SCREEN GRID ICF

1720 E. CURRY RD.  
 TEMPE ARIZONA 85281  
<http://www.efbm.com/>

- ① ICCF BLOCK- TYP. 5' LENGTH W/  
GROUTED CELLS @ 12" O.C. AND #4  
REBAR @ 48" O.C. HORIZ. MAX
- ② #4 REBAR @ 48" O.C. VERT. MAX
- ③ ICF CORNER- DIMENSIONS AS NOTED
- ④ ICF BLOCK- CUT TO ALLOW CLEAN  
JOINT TO CORNER

**NOTE:**  
ICF SCREEN GRID TO BE PER CURRENT  
IRC FOOTING WIDTH, REBAR SIZE AND  
SPACING  
PER SECTION R608 - IRC

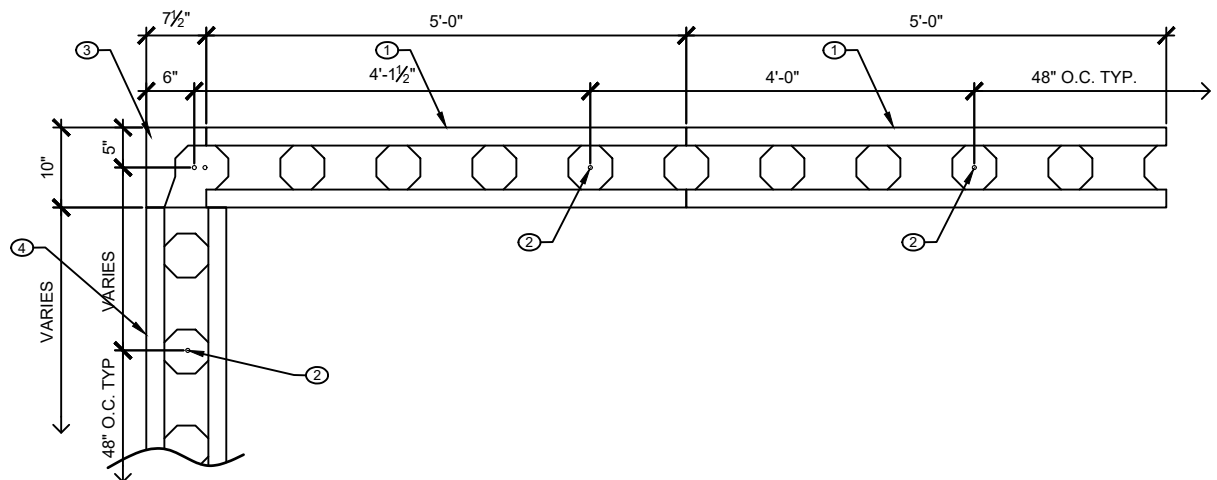

DRAWN	KD
CHECKED	
DATE	06-22-20
SCALE	3/4" = 1'-0"
FILE NAME	EF BLOCK
DETAILS	
SHEET	D.13
	1 OF 1 SHEETS

ICF CORNER  
12" O.C. SCREEN GRID ICF

1720 E. CURRY RD.  
TEMPE ARIZONA 85281  
<http://www.efbm.com/>



# LINTEL SCHEDULE

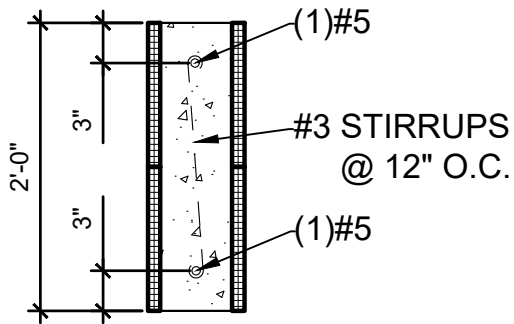

**DETAIL FOR L-2**

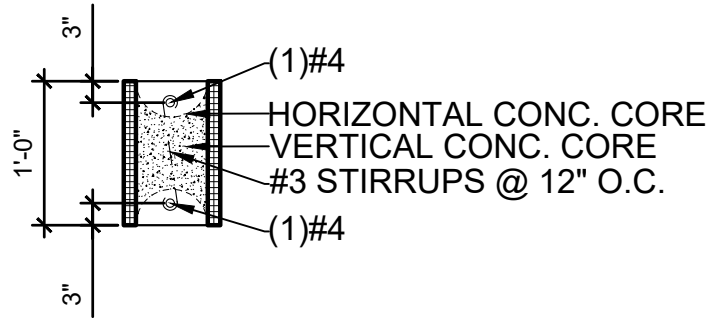

**DETAIL FOR L-1**

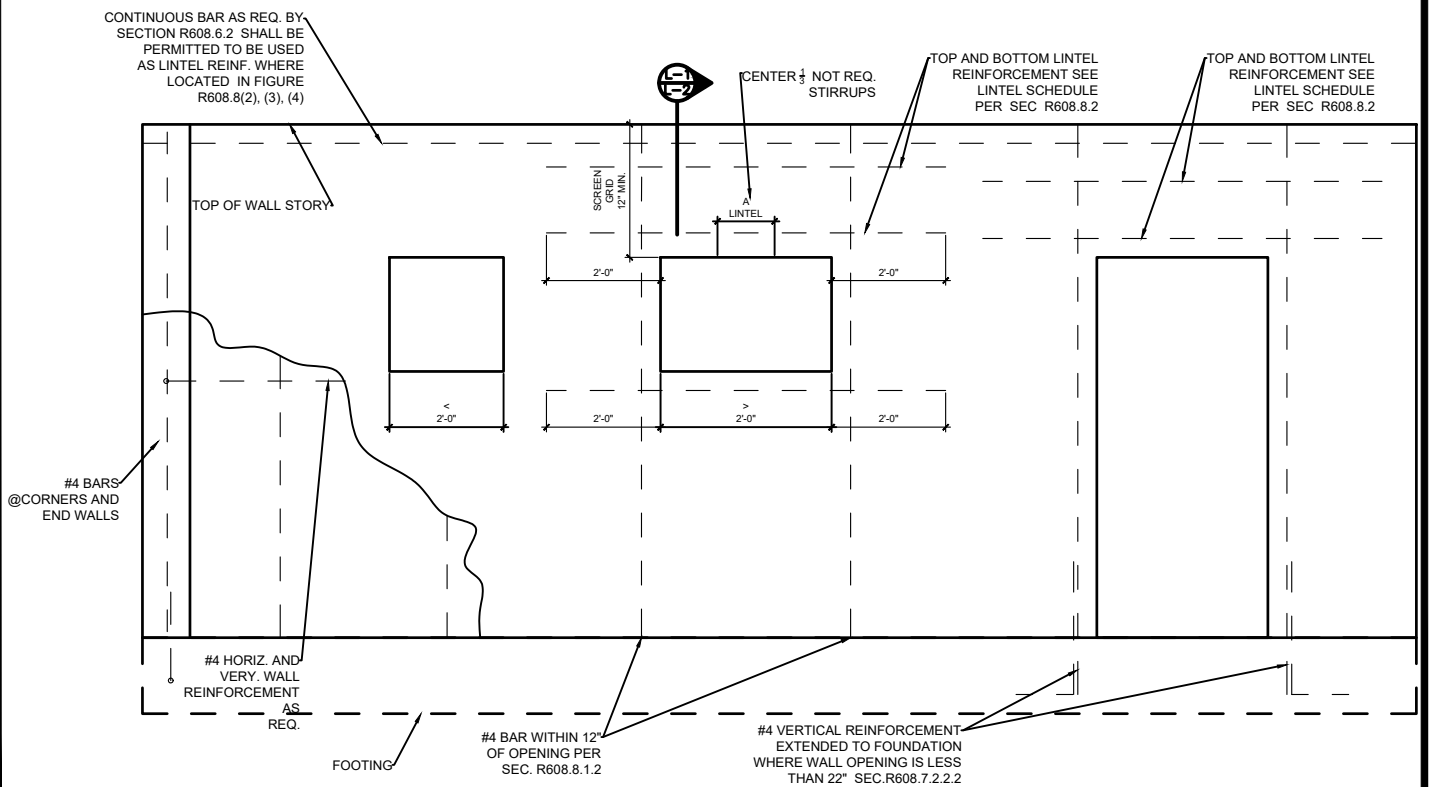

**6" SCREEN-GRID WALL REINFORCEMENT**

BASED ON TABLE R608.7(4) FIGURE R608.8(1) FIGURE 608.7(3) SEC. R608.7.2.2.2  
SEC. R608.7.2.2.1, SEC R608.8.1.2 CURRENT I.R.C.

DRAWN	MD
CHECKED	
DATE	06-22-20
SCALE	N.T.S.
EF BLOCK	
FILE NAME	DETAILS
SHEET	D.14
1 OF 1 SHEETS	

## WALL REINFORCEMENT 12" O.C. SCREEN GRID ICF

1720 E. CURRY RD.  
TEMPE ARIZONA 85281  
<http://www.efbm.com/>

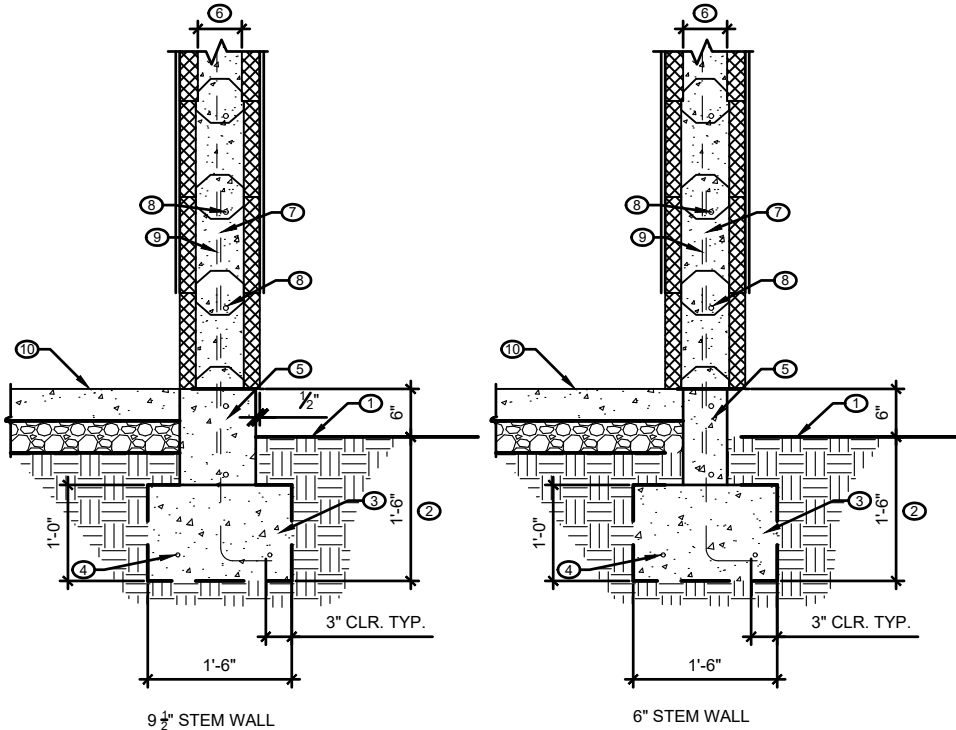
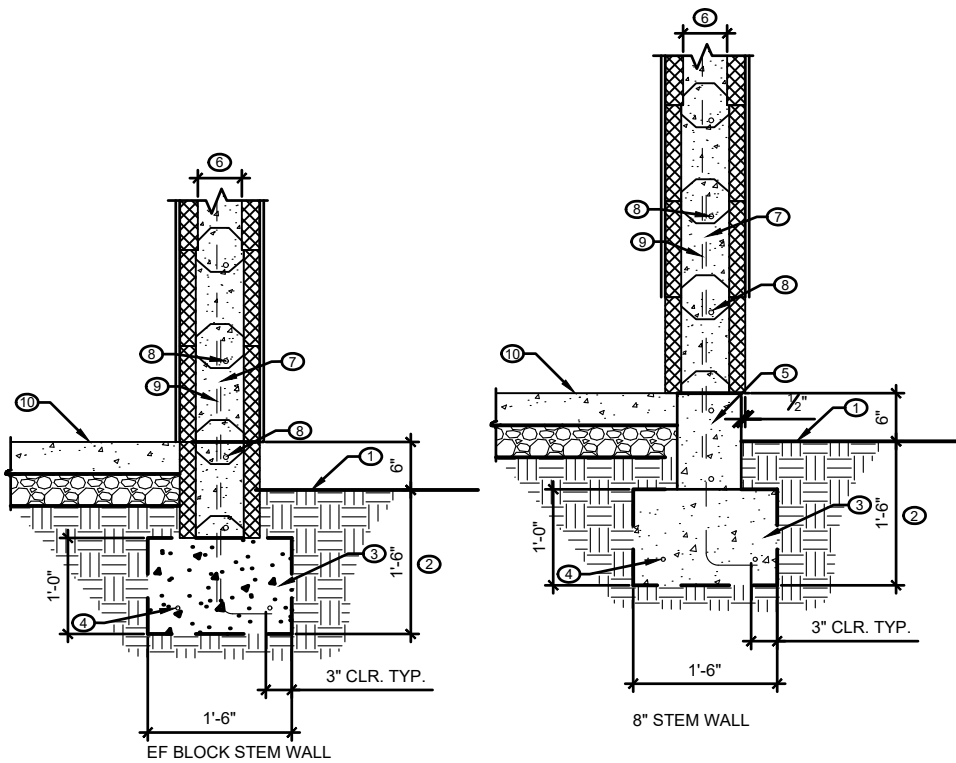

- ① FINISHED GRADE
  - ② 16" MINIMUM BELOW FINISH GRADE
  - ③ 18X 12 FOOTING W BOTTOM -1'-6" BELOW GRADE
  - ④ (2) #4 CONT.
  - ⑤ FOOTING STEM WALL WITH CONTINUOUS #4 BAR TOP AND BOTTOM
  - ⑥ ICF CONCRETE CORE THICKNESS 6"
  - ⑦ VERTICAL DOWELS TO MATCH ICF WALL VERTICAL REINFORCING ALTERNATE BENDS
  - ⑧ HORIZONTAL REINFORCING 48" O.C. MAX
  - ⑨ VERTICAL REINFORCING 48" O.C. MAX
  - ⑩ 4" THICK CONCRETE SLAB OVER 4" ABC FILL
- Ⓐ ACTUAL REBAR QUANTITY MAY DIFFER FROM DRAWN DETAIL. (1) TOP OR BOTTOM BAR SHALL BE CENTER ON FTG WIDTH, (3) OR MORE BARS SHALL BE SPACE EVENLY
- Ⓑ LAP REINFORCING BARS PER 40 DIAMETERS
- Ⓒ FOOTING STEM WIDTH MAY BE DECREASED TO MATCH ICF CONCRETE CORE THICKNESS AT CONTRACTORS DISCRETION

**NOTE:**  
 ICF SCREEN GRID TO BE PER CURRENT IRC FOOTING WIDTH, REBAR SIZE AND SPACING  
 PER SECTION R608 - IRC

DRAWN	MD
CHECKED	
DATE	06-22-20
SCALE	N.T.S.
PROJECT	EF BLOCK
FILE NAME	DETAILS
SHEET	D.15
	1 OF 1 SHEETS

ICF WALL @ CONT. FOOTING  
 12" O.C. SCREEN GRID ICF

1720 E. CURRY RD.  
 TEMPE ARIZONA 85281  
<http://www.efbm.com/>



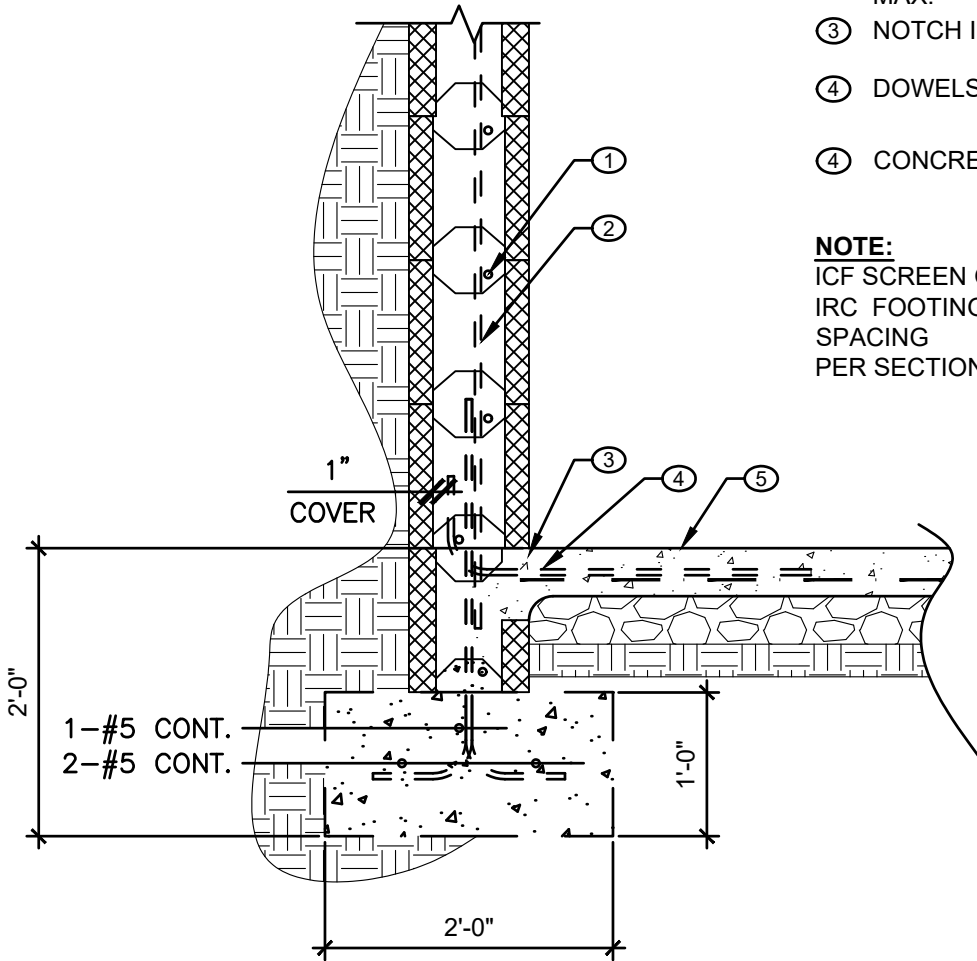

- ① HORIZONTAL REINFORCING # 4 @ 48"O.C. MAX.
- ② VERTICAL REINFORCING # 4 @ 48"O.C. MAX.
- ③ NOTCH IN BLOCK @ DOWELS
- ④ DOWELS @ 24" O.C. 8"  $\left\{ \begin{array}{l} \\ 30" \end{array} \right.$
- ⑤ CONCRETE SLAB

**NOTE:**  
 ICF SCREEN GRID TO BE PER CURRENT IRC FOOTING WIDTH, REBAR SIZE AND SPACING  
 PER SECTION R608 - IRC

DRAWN	MD
CHECKED	
DATE	06-22-20
SCALE	1/2" = 1'-0"
EF BLOCK	
FILE NAME	DETAILS
SHEET	D.17
1	OF 1 SHEETS

RETAINING WALL BLOCK DET.  
 12" O.C. SCREEN GRID ICF

1720 E. CURRY RD.  
 TEMPE ARIZONA 85281  
<http://www.efbm.com/>

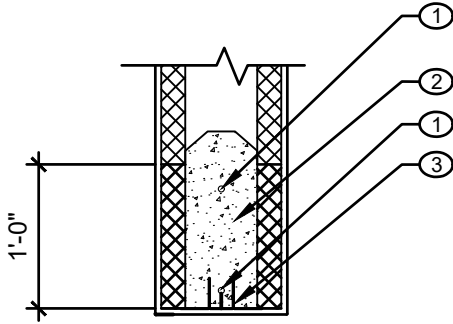

- ① #4 REBAR
- ② GROUT
- ③ POWERS PS8-12" LINTEL

**NOTE:**  
 ICF SCREEN GRID TO BE PER CURRENT  
 IRC FOOTING WIDTH, REBAR SIZE AND  
 SPACING  
 PER SECTION R608 - IRC

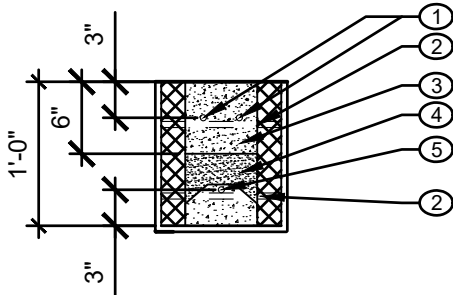

- ① 2- #5 BAR
- ② #3 @ 24" O.C.
- ③ GROUT
- ④ VERTICAL CONC. CORE
- ⑤ 1- #4

**NOTE:**  
 ICF SCREEN GRID TO BE PER CURRENT  
 IRC FOOTING WIDTH, REBAR SIZE AND  
 SPACING  
 PER SECTION R608 - IRC

DETAIL FOR L-1

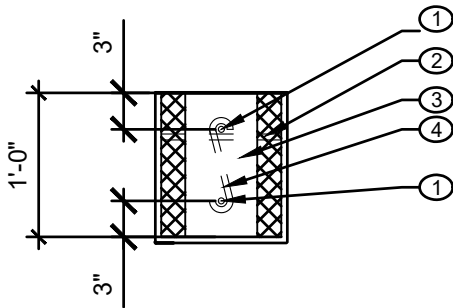

- ① 1- #5 BAR
- ② #3 @ 24" O.C.
- ③ GROUT
- ④ #3 STIRRUPS @ 12" O.C.

**NOTE:**  
 ICF SCREEN GRID TO BE PER CURRENT  
 IRC FOOTING WIDTH, REBAR SIZE AND  
 SPACING  
 PER SECTION R608 - IRC

DETAIL FOR L-2

OPTIONAL LINTEL DETAILS  
 12" O.C. SCREEN GRID ICF

DRAWN	KD
CHECKED	
DATE	06-22-20
SCALE	1/2" = 1'-0"
PROJECT	EF BLOCK
FILE NAME	DETAILS
SHEET	D.18
1 OF 1 SHEETS	

1720 E. CURRY RD.  
 TEMPE ARIZONA 85281  
<http://www.efbm.com/>



## IRC 2018 12" O.C. ICF SCREEN GRID NOTES:

1. ICF TO BE PER IRC 2018 ICF SCREEN GRID.
2. SCREEN GRID ICF MUST BE GROUTED SOLID WITH A MINIMUM OF 2500 PSI, 3/8" MINUS GROUT PER SECTION R608 OF THE IRC 2018.
3. PLACING THE CONCRETE IN THE CORES MUST BE ACCOMPLISHED IN ACCORDANCE WITH SECTION R608 OF THE IRC 2018.
4. ENFORCING  $f_y = 40,000$  PSI A-615 GRADE 40. UNLESS NOTED OTHERWISE. SEE 2018IRC SCREEN GRID PRESCRIPTIVE DESIGN.
5. THE CONCRETE GROUT MUST HAVE A MINIMUM COMPRESSIVE STRENGTH OF 2500 PSI AFTER 28 DAYS WITH A SLUMP OF 6' TO 7". PER SECTION R608 OF THE IRC 2018.
6. ICF MAY BE ERECTED EITHER VERTICAL OR HORIZONTAL AND REINFORCING AS REQUIRED PER SECTION R608 OF THE IRC 2018.
7. ICF WALLS MUST BE ADEQUATELY BRACED PER SECTION R608 OF THE IRC 2018 TO RESIST LATERAL FORCE DURING CONCRETE POUR.
8. ALL CELLS TO BE GROUTED SOLID PER SECTION R608 OF THE IRC2018.
9. VERTICAL AND HORIZONTAL ENFORCING SPACING SHALL BE A MINIMUM OF 48" O.C. UNLESS NOTED OTHERWISE. SEE SECTION R608 OF THE 2018 IRC SCREEN GRID PRESCRIPTIVE DESIGN FOR SIZE OF ENFORCING.

DRAWN KD
CHECKED
DATE 06-22-20
SCALE 1/2" = 1'-0"
EF BLOCK
FILE NAME DETAILS
SHEET D.19
1 OF 1 SHEETS

2018 IRC NOTES  
12" O.C. SCREEN GRID ICF

1720 E. CURRY RD.  
TEMPE ARIZONA 85281  
<http://www.efbm.com/>



## IRC 2012 12" O.C. ICF SCREEN GRID NOTES:

1. ICF TO BE PER IRC 2012 ICF SCREEN GRID.
2. SCREEN GRID ICF MUST BE GROUTED SOLID WITH A MINIMUM OF 2500 PSI, 3/8" MINUS GROUT PER SECTION R611 OF THE IRC 2012.
3. PLACING THE CONCRETE IN THE CORES MUST BE ACCOMPLISHED IN ACCORDANCE WITH SECTION R611 OF THE IRC 2012.
4. ENFORCING  $f_y = 40,000$  PSI A-615 GRADE 40. UNLESS NOTED OTHERWISE. SEE 2012IRC SCREEN GRID PRESCRIPTIVE DESIGN.
5. THE CONCRETE GROUT MUST HAVE A MINIMUM COMPRESSIVE STRENGTH OF 2500 PSI AFTER 28 DAYS WITH A SLUMP OF 6' TO 7". PER SECTION R611 OF THE IRC 2012.
6. ICF MAY BE ERECTED EITHER VERTICAL OR HORIZONTAL AND REINFORCING AS REQUIRED PER SECTION R611 OF THE IRC 2012.
7. ICF WALLS MUST BE ADEQUATELY BRACED PER SECTION R611 OF THE IRC 2012 TO RESIST LATERAL FORCE DURING CONCRETE POUR.
8. ALL CELLS TO BE GROUTED SOLID PER SECTION R611 OF THE IRC2012.
9. VERTICAL AND HORIZONTAL ENFORCING SPACING SHALL BE A MINIMUM OF 48" O.C. UNLESS NOTED OTHERWISE. SEE SECTION R611 OF THE 2012 IRC SCREEN GRID PRESCRIPTIVE DESIGN FOR SIZE OF ENFORCING.

DRAWN
RD
CHECKED
DATE
06-22-20
SCALE
1/2" = 1'-0"
FILE NAME
EF BLOCK
DETAILS
SHEET
D.20
1 OF 1 SHEETS

2012IRC NOTES  
12" O.C. SCREEN GRID ICF

1720 E. CURRY RD.  
TEMPE ARIZONA 85281  
<http://www.efbm.com/>



## IRC 2021 12" O.C. ICF SCREEN GRID NOTES:

1. ICF TO BE PER IRC 2021 ICF SCREEN GRID.
2. SCREEN GRID ICF MUST BE GROUTED SOLID WITH A MINIMUM OF 2500 PSI, 3/8" MINUS GROUT PER SECTION R608 OF THE IRC 2021.
3. PLACING THE CONCRETE IN THE CORES MUST BE ACCOMPLISHED IN ACCORDANCE WITH SECTION R608 OF THE IRC 2021.
4. ENFORCING  $f_y = 40,000$  PSI A-615 GRADE 40. UNLESS NOTED OTHERWISE. SEE 2021 IRC SCREEN GRID PRESCRIPTIVE DESIGN.
5. THE CONCRETE GROUT MUST HAVE A MINIMUM COMPRESSIVE STRENGTH OF 2500 PSI AFTER 28 DAYS WITH A SLUMP OF 6' TO 7". PER SECTION R608 OF THE IRC 2021.
6. ICF MAY BE ERECTED EITHER VERTICAL OR HORIZONTAL AND REINFORCING AS REQUIRED PER SECTION R608 OF THE IRC 2021.
7. ICF WALLS MUST BE ADEQUATELY BRACED PER SECTION R608 OF THE IRC 2021 TO RESIST LATERAL FORCE DURING CONCRETE POUR.
8. ALL CELLS TO BE GROUTED SOLID PER SECTION R608 OF THE IRC 2021.
9. VERTICAL AND HORIZONTAL ENFORCING SPACING SHALL BE A MINIMUM OF 48" O.C. UNLESS NOTED OTHERWISE. SEE SECTION R608 OF THE 2021 IRC SCREEN GRID PRESCRIPTIVE DESIGN FOR SIZE OF ENFORCING.

DESIGN	KD
CHECKED	
DATE	08-28-20
SCALE	3/4" = 1'-0"
IF BLOCK	
FILE NAME	
DETAILS	
SHEET	
D.35	
1	OF 1 SHEETS

## 2021 IRC NOTES

### 12" O.C. SCREEN GRID ICF

1720 E. CURRY RD.  
TEMPE ARIZONA 85281  
<http://www.efbm.com/>



## IRC 2024 12" O.C. ICF SCREEN GRID NOTES:

1. ICF TO BE PER IRC 2024 ICF SCREEN GRID.
2. SCREEN GRID ICF MUST BE GROUTED SOLID WITH A MINIMUM OF 2500 PSI, 3/8" MINUS GROUT PER SECTION R608 OF THE IRC 2024.
3. PLACING THE CONCRETE IN THE CORES MUST BE ACCOMPLISHED IN ACCORDANCE WITH SECTION R608 OF THE IRC 2024.
4. ENFORCING  $f_y = 40,000$  PSI A-615 GRADE 40. UNLESS NOTED OTHERWISE. SEE 2024 IRC SCREEN GRID PRESCRIPTIVE DESIGN.
5. THE CONCRETE GROUT MUST HAVE A MINIMUM COMPRESSIVE STRENGTH OF 2500 PSI AFTER 28 DAYS WITH A SLUMP OF 6' TO 7". PER SECTION R608 OF THE IRC 2024.
6. ICF MAY BE ERECTED EITHER VERTICAL OR HORIZONTAL AND REINFORCING AS REQUIRED PER SECTION R608 OF THE IRC 2024.
7. ICF WALLS MUST BE ADEQUATELY BRACED PER SECTION R608 OF THE IRC 2024 TO RESIST LATERAL FORCE DURING CONCRETE POUR.
8. ALL CELLS TO BE GROUTED SOLID PER SECTION R608 OF THE IRC2024.
9. VERTICAL AND HORIZONTAL ENFORCING SPACING SHALL BE A MINIMUM OF 48" O.C. UNLESS NOTED OTHERWISE. SEE SECTION R608 OF THE 2024 IRC SCREEN GRID PRESCRIPTIVE DESIGN FOR SIZE OF ENFORCING.

DESIGN	NO
CHECKED	
DATE	08-28-24
SCALE	3/4" = 1'-0"
IF BLOCK	
FILE NAME	
DETAILS	
SHEET	
D.36	
1 OF 1 SHEETS	

2024 IRC NOTES  
12" O.C. SCREEN GRID ICF

1720 E. CURRY RD.  
TEMPE ARIZONA 85281  
<http://www.efbm.com/>



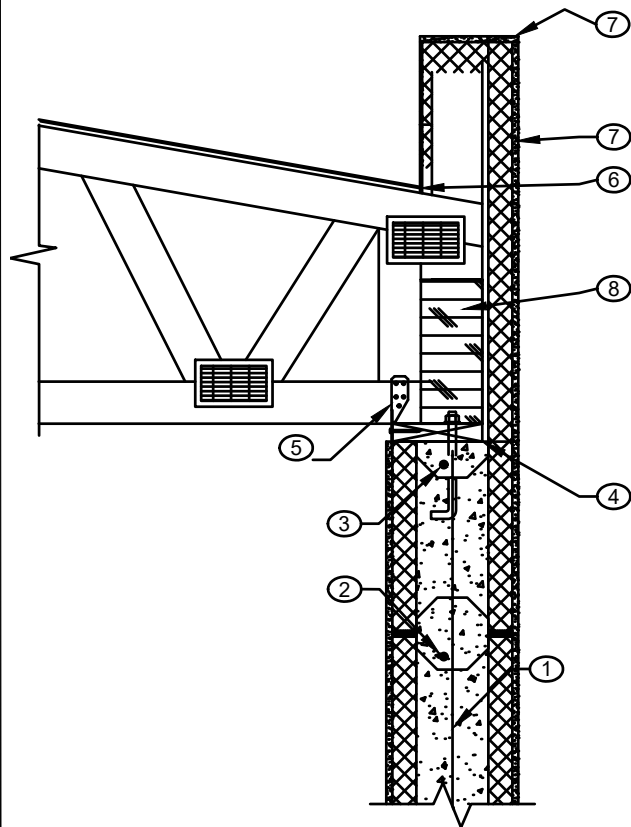

- ① VERTICAL REINFORCING # 4 @ 48"O.C. MAX.
- ② HORIZONTAL REINFORCING # 4 @ 48"O.C. MAX.
- ③ BOND BEAM WITH (1) #4 CONTINUOUS BAR
- ④ 2X TOP PLATE WITH 1/2" DIAMETER ANCHOR BOLTS AT 48" O.C.
- ⑤ H2.5 CLIP TO EACH ROOF TRUSS. FASTENED DIRECTLY TO TOP NAILER
- ⑥ STRUCTURAL SHEATHING W/ 30# FELT
- ⑦ FOAM EPS WITH LATH OVERLAPPING ICF MIN. 12"
- ⑧ GLB PER PLANS

**NOTE:**

ICF SCREEN GRID TO BE PER CURRENT IRC FOOTING WIDTH, REBAR SIZE AND SPACING PER SECTION R608 - IRC

DRAWN	KD
CHECKED	
DATE	06-22-20
SCALE	1/2" = 1'-0"
FILE NAME	EF BLOCK
DETAILS	
SHEET	D.22
	1 OF 1 SHEETS

GLB TOP CHORD BRNG  
12" O.C. SCREEN GRID ICF

1720 E. CURRY RD.  
TEMPE ARIZONA 85281  
<http://www.efbm.com/>

- ① VERTICAL REINFORCING PER CURRENT IRC
- ② SIMPSON GLB5A
- ③ GLB PER DESIGN

**NOTE:**  
 ICF SCREEN GRID TO BE PER CURRENT  
 IRC FOOTING WIDTH, REBAR SIZE AND  
 SPACING PER SECTION R608 - IRC

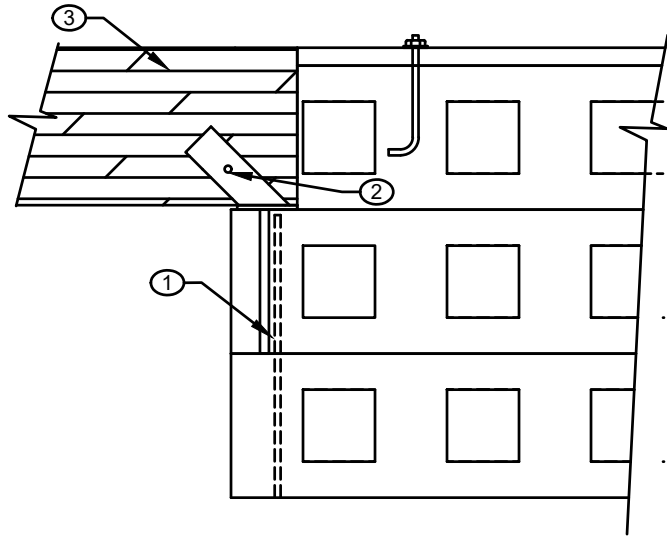

DRAWN
KD
CHECKED
DATE
06-22-20
SCALE
1/2" = 1'-0"
EF BLOCK
FILE NAME
DETAILS
SHEET
D.23
1 OF 1 SHEETS

GLB PARALLEL TO WALL  
 12" O.C. SCREEN GRID ICF

1720 E. CURRY RD.  
 TEMPE ARIZONA 85281  
<http://www.efbm.com/>

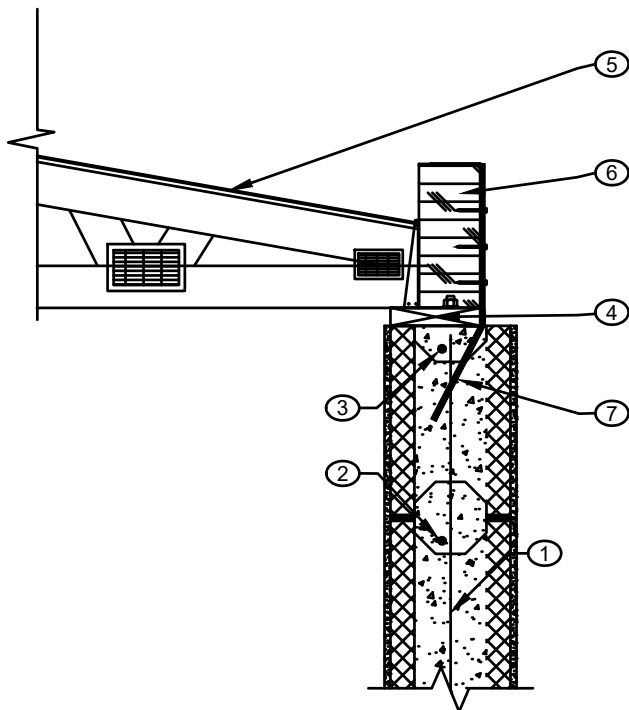

- ① HORIZONTAL REINFORCING # 4 @ 48"O.C. MAX.
- ② VERTICAL REINFORCING # 4 @ 48"O.C. MAX.
- ③ BOND BEAM WITH (1) #4 CONTINUOUS BAR
- ④ 2X TOP PLATE WITH 1/2" DIAMETER ANCHOR BOLTS AT 48" O.C.
- ⑤ STRUCTURAL SHEATHING W/ 30# FELT
- ⑥ GLB PER PLANS
- ⑦ PA STRAP

**NOTE:**

ICF SCREEN GRID TO BE PER CURRENT IRC FOOTING WIDTH, REBAR SIZE AND SPACING PER SECTION R608 - IRC

DRAWN	KD
CHECKED	
DATE	06-22-20
SCALE	1/2" = 1'-0"
FILE NAME	EF BLOCK
DETAILS	
SHEET	D.24
	1 OF 1 SHEETS

ALT. GLB BOT CHORD BEARING  
12" O.C. SCREEN GRID ICF

1720 E. CURRY RD.  
TEMPE ARIZONA 85281  
<http://www.efbm.com/>

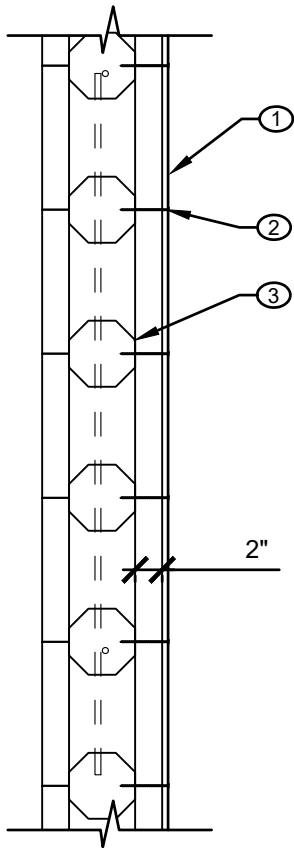

- ① 2 1/2" x 1/2" OSB STRIPS @ 16" O.C.
- ② 16d RING SHANK DECK NAIL @ 12" O.C. INTO CONC. CORE
- ③ ICF BLOCK

**NOTE:**  
 ICF SCREEN GRID TO BE PER CURRENT IRC FOOTING WIDTH, REBAR SIZE AND SPACING  
 PER SECTION R608 - IRC

DRAWN	KD
CHECKED	
DATE	04-13-21
SCALE	3/4" = 1'-0"
EF BLOCK	
FILE NAME	DETAILS
SHEET	D.26
1 OF 1 SHEETS	

OSB STRIPS FOR METAL SIDING  
 12" O.C. SCREEN GRID ICF

1720 E. CURRY RD.  
 TEMPE ARIZONA 85281  
<http://www.efbm.com/>

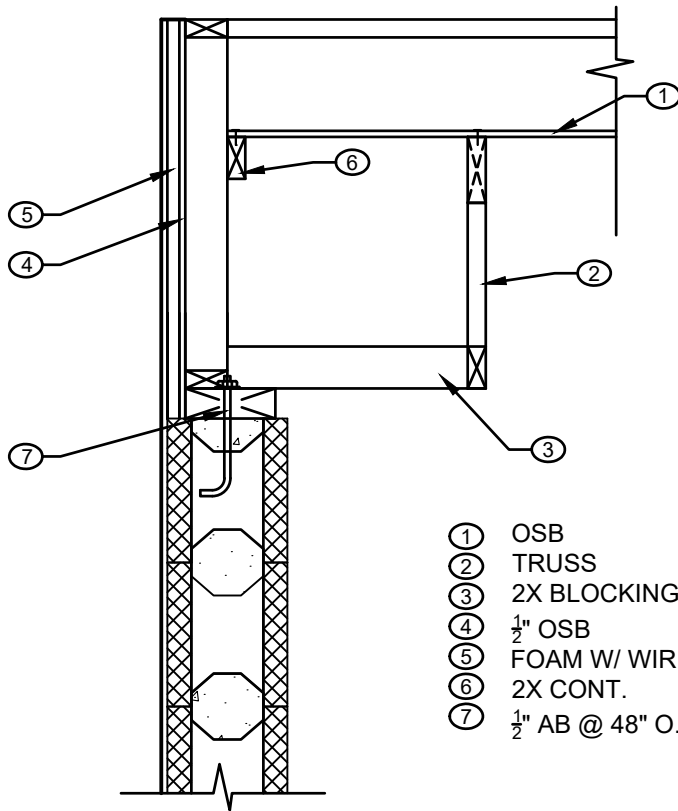

- ① OSB
- ② TRUSS
- ③ 2X BLOCKING @ 24" O.C.
- ④ 1/2" OSB
- ⑤ FOAM W/ WIRE OVER TAR PAPER
- ⑥ 2X CONT.
- ⑦ 1/2" AB @ 48" O.C. MAX

TRUSS PARALLEL TO ICF WALL  
 12" O.C. SCREEN GRID ICF

1720 E. CURRY RD.  
 TEMPE ARIZONA 85281  
<http://www.efbm.com/>



DRAWN	KD
CHECKED	
DATE	02-27-25
SCALE	3/4" = 1'-0"
FILE NAME	EF BLOCK
DETAILS	
SHEET	D.28
1 OF 1 SHEETS	

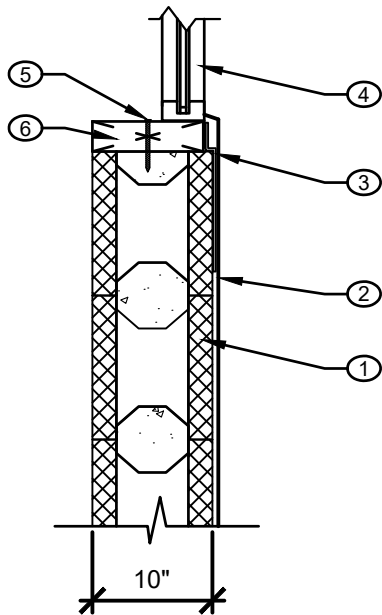

- ① EF BLOCK
- ② STUCCO
- ③ CHICKEN WIRE STAPLED TO EF BLOCK WITH 12" LAP
- ④ NAIL FIN WINDOW W/FLASHING
- ⑤ LAG BOLT OR SCREW
- ⑥ 2X10 WOOD BLOCK

DRAWN
KD
CHECKED
DATE
02-27-25
SCALE
3/4" = 1'-0"
FILE NAME
EF BLOCK
DETAILS
SHEET
D.29
1 OF 1 SHEETS

WINDOW DETAIL (EXTERIOR)  
12" O.C. SCREEN GRID ICF

1720 E. CURRY RD.  
TEMPE ARIZONA 85281  
<http://www.efbm.com/>

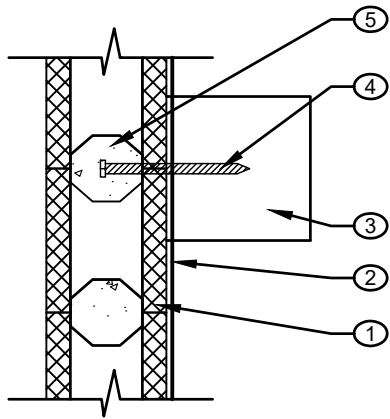

- ① EF BLOCK
- ② STUCCO
- ③ VIGA
- ④ 12" LAG BOLT OR REBAR
- ⑤ GROUTED CELL

DRAWN	KD
CHECKED	
DATE	02-27-25
SCALE	3/4" = 1'-0"
FILE NAME	EF BLOCK
DETAILS	DETAILS
SHEET	D.30
1 OF 1 SHEETS	

VIGA ATTACHMENT  
12" O.C. SCREEN GRID ICF

1720 E. CURRY RD.  
TEMPE ARIZONA 85281  
<http://www.efbm.com/>

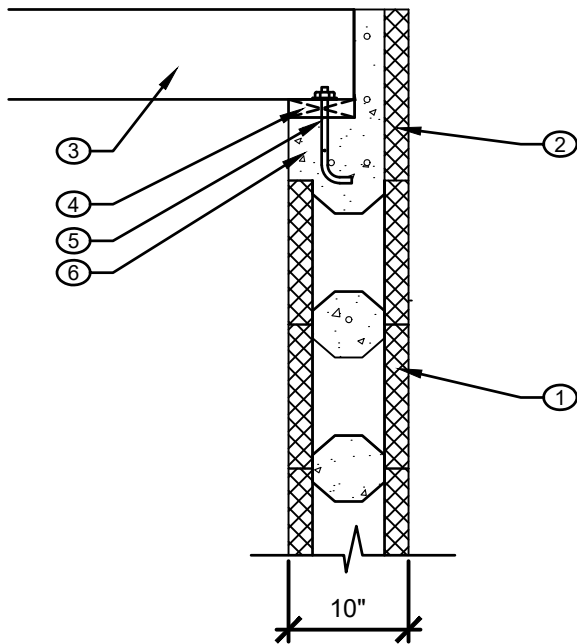

- ① EF BLOCK
- ② EF FLAT PANEL
- ③ FLOOR JOIST
- ④ 2X TOP PLATE
- ⑤ ANCHOR BOLT 8" EMBED
- ⑥ CONCRETE

DRAWN
KD
CHECKED
DATE
02-27-25
SCALE
3/4" = 1'-0"
PROJECT
EF BLOCK
FILE NAME
DETAILS
SHEET
D.31
1 OF 1 SHEETS

FLOOR JOIST @ NOTCHED WALL  
 12" O.C. SCREEN GRID ICF

1720 E. CURRY RD.  
 TEMPE ARIZONA 85281  
<http://www.efbm.com/>